

## Installation and Operating Instructions for the NMEA Filter (RS422/232)

The Filter accepts a 4800 baud NMEA input and has two NMEA output modes: -

- a buffered unaltered output and a 'desired sentence' output or
- a filtered output signal with selectively blocked sentences.

Both input and output can be RS232 or RS422. The power supply, input and outputs are isolated from each other. **(Note the outputs are independent but not isolated from each other. Connecting different DC levels to the outputs will damage the unit.)**

Programming can be either customer specified or easily changed during installation using Windows HyperTerminal or a similar communications program. The programming information is retained in EEPROM (memory) and not lost if the power is removed from the unit.

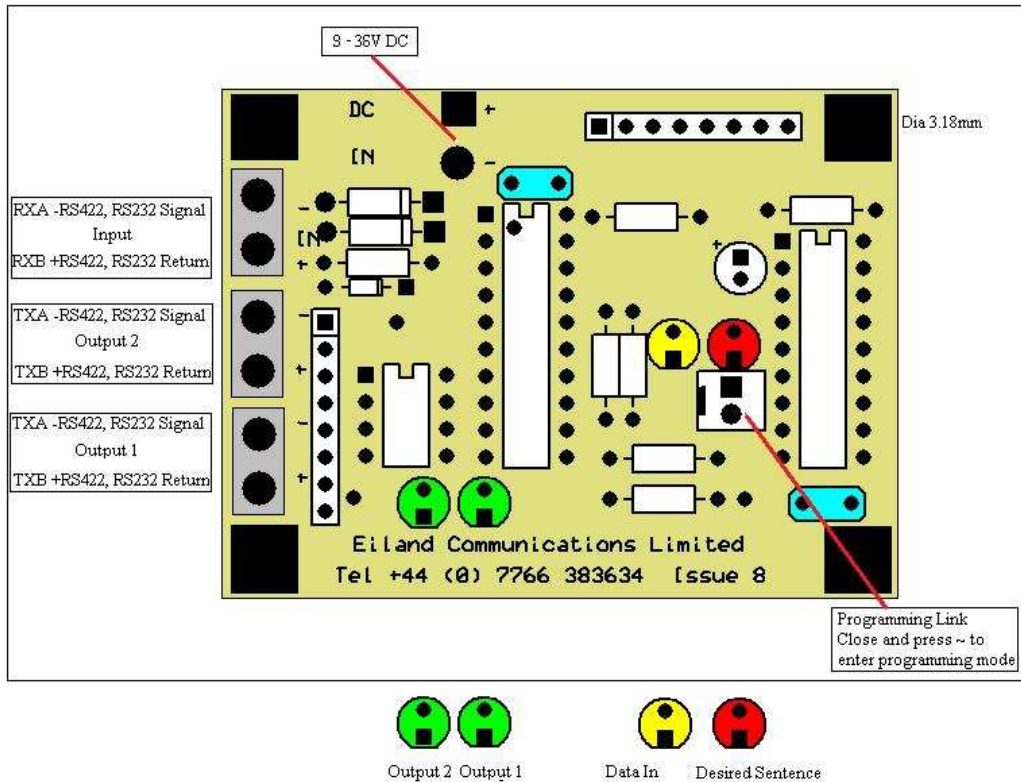

### Filtering

Output 1 passes the entire data stream as received at the input including the desired sentence. The data is buffered, unaltered and in real time. A green led shows activity at the output.

Output 2 consists exclusively of the user programmed desired sentence (e.g. GPGLL) filtered from the input data. The output sentence is stored briefly, verified against the checksum and then immediately re-transmitted. A red led will flash when this happens. A green led shows activity at the output.

## Blocking

The Filter can be programmed to block a NMEA sentence or group of sentences e.g. \$HEHDT or all sentences beginning \$HE or \$HEH or \$HEHD.

Output 1 passes the entire data stream as it was received at the input but is interrupted once a blocked sentence is detected. The data is buffered through logic gates and transmitted in real time. A green led shows activity at the output.

Output 2 is not used.

## Programming the NMEA Filter.

Unless specified otherwise the unit is supplied without the ability to pass or block any sentence.

The unit is programmed using Windows HyperTerminal or similar. Using the lead supplied plug the 9-way D connector into a PC serial port e.g. COM 1 and the grey connectors into the input and output 2 connections. **The green-black is the input to the PCB and the white-black connects to Output2.**

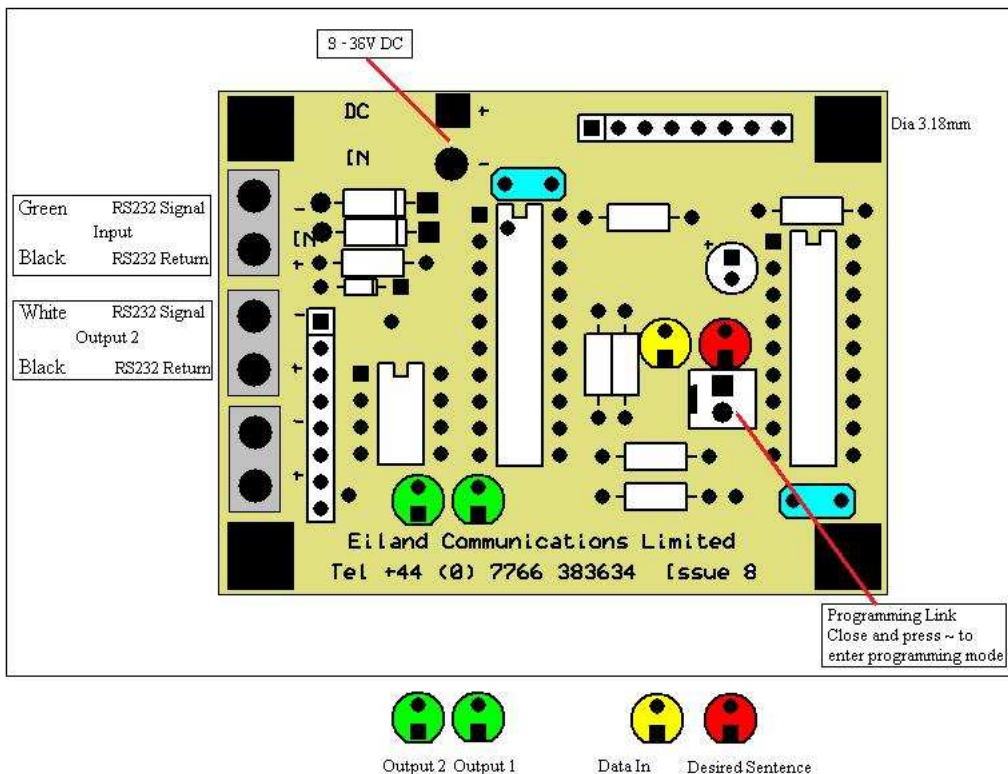

Use Windows HyperTerminal with the following settings.



In the ASCII set-up select 'echo typed characters locally' so that you can see exactly what is happening.

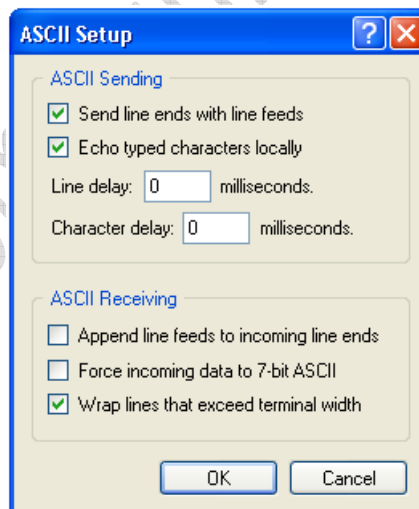

### Set-up Mode

With the programming link in place type a ~ (tilde) character into HyperTerminal on the computer. The red led will light continuously indicating set-up mode.

Type a 1 to change the set-up.

Enter the 5 characters of the desired sentence followed by a + (plus) sign, e.g. HEHDT+. Note you have to type the characters in the correct case; hehdt+ would not filter out HEHDT.

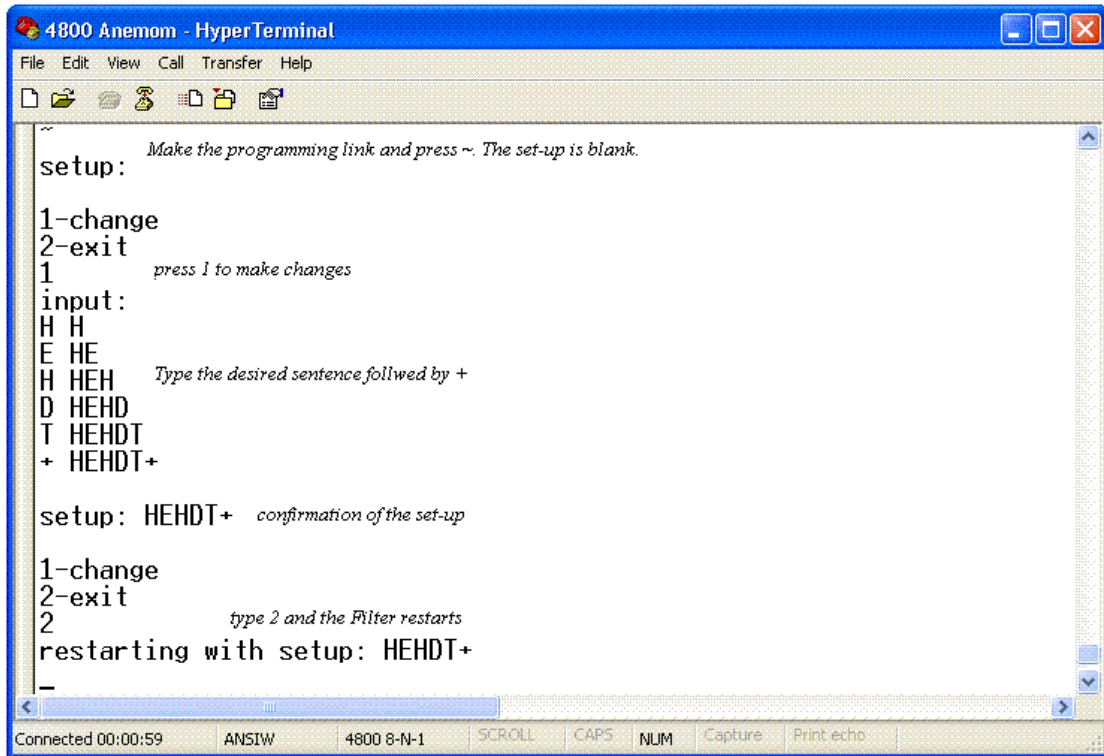

You then receive confirmation of the changes. Press 1 to change the set-up again or press 2 on the keyboard to save the changes and the Filter automatically restarts.

The desired sentence will appear at output 1 and the red led will flash for each transmission, the entire data input will appear unchanged at output 2.

### To block a sentence at output t

Enter up to 5 characters of the blocked sentence or sentences by placing a – (minus sign) after the last character of the string you want to block. E.g.

GP---- will block all sentences beginning with GP.

GPR--- would block GPRMC and GPRMB but pass GPGLL and GPGGA

GPGLL- will block just the GPGLL sentence

(In actual fact the characters will be transmitted initially but as soon as the processor detects them the transmission is blocked until the next sentence is received at the input)

You then receive confirmation of the changes. You then receive confirmation of the changes. Press 1 to change the set-up again or press 2 on the keyboard to save the changes and the Filter automatically restarts.

Output 1 is not used; the entire data input less any blocked sentences will appear at output 2.

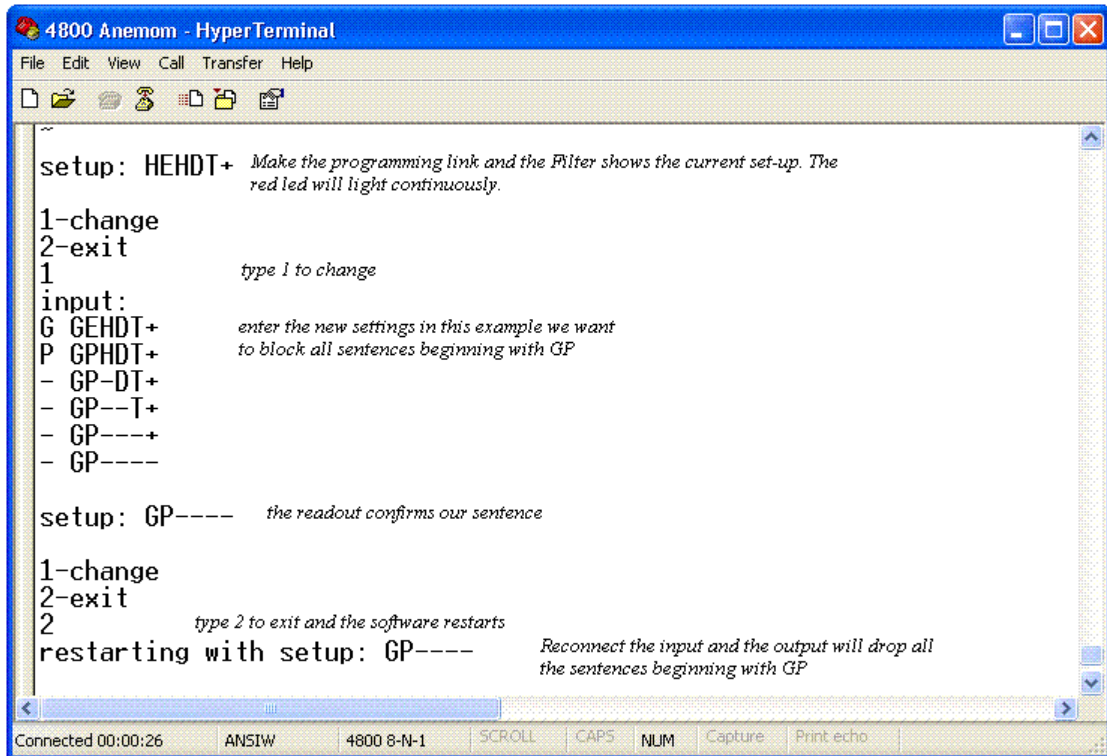

## Testing the NMEA Filter

You can now test the unit still using the HyperTerminal program in Windows.

### Filtering

Without going in to programming mode type (continuing our example) \$HEHDT,100.5,T\*2B, the led will flash once and you should get echoed back from output 2 \$HEHDT,100.5,T\*2B.

All other sentences and combinations of characters should be rejected.

### Blocking

Move the PC receive connector from output 2 to output 1. Type \$GPR and you should only get \$GP. Type a \* (this tells the Filter that the blocked \$GP sentence has finished and to expect a new sentence) and then type \$HEHDT,100.5,T\*2B or anything except \$GP which should be echoed back to the PC.

You are now ready to connect up the NMEA Filter or put it back into service after changing the set-up. Disconnect the NMEA Filter from your PC.

**Remove the programming link to prevent the Filter inadvertently entering programming mode during use. If you are experimenting with the set-up you can leave the link in place until you finally put the Filter into service.**

## Installation

Connect the NMEA input to 'IN' pins - and + (For RS422 - is -RS422 or RXA, + is +RS422 or RXB, for RS232 connect the signal to - and the return to +).

Connect the power and the red led will flash on for one second.

If data is present then the green output 1 led should flash. If you are filtering and the desired sentence is in the data stream the red led should also flash as will the green led on output 2.

**If the red led does not flash and you are certain the desired sentence is included in the input data stream try reversing the connections at the input.**

Switch off. Connect the NMEA outputs to pins - and + (For RS422 - is -RS422 or RXA, + is +RS422 or RXB, for RS232 connect the signal to - and the return to +).

Reconnect the power and the desired sentence should be delivered to the NMEA load, the led flashing as each sentence is transmitted.

#### Notes on Usage

Caution should be exercised in determining the purpose to which the NMEA Filter is put. For example it should not be used to modify sentences in 'critical' systems, or where the approval certification of any equipment is violated by use of the filter. You may also have to consider the power source for the filter in event of mains failure.

#### Terminations

Power	9 to 36V DC reverse polarity protected. Isolated from ground and the data input/outputs.
Input	RS232 or RS422 opto-isolated NMEA 0183 4800 baud (9600 baud is available as an alternative, pass though at 9600).
Outputs x 2	RS232 or RS422 compatible NMEA 0183 4800. Short circuit protected. (9600 baud filtered output available as an alternative).
Link	When closed the input of the ~ character enters the set-up mode

#### Indicators

Red led	Flashes for one second at power up On steady during set-up mode Flashes each time a desired sentence is re-transmitted.
Yellow led	Flashes when data is received at the input
Green led x 2	Flashes when data is at the respective output.

#### Physical

PCB Size	63mm x 47mm
----------	-------------